

4.5.3 **Type 160: Advanced Alkaline Electrolyzer**

Type 160 is a mathematical model for a high pressure alkaline water electrolyzer. The model is based on a combination of fundamental thermodynamics, heat transfer theory, and empirical electrochemical relationships. A dynamic thermal model is also included. A temperature dependent current-voltage curve for a given pressure, and a Faraday efficiency relation independent of temperature and pressure form the basis of the electrochemical model. The electrolyzer temperature can be given as Input, or calculated from a simple or detailed thermal model [1,2].

A principle scheme of an electrolyzer is shown in Figure 4.5.3–1

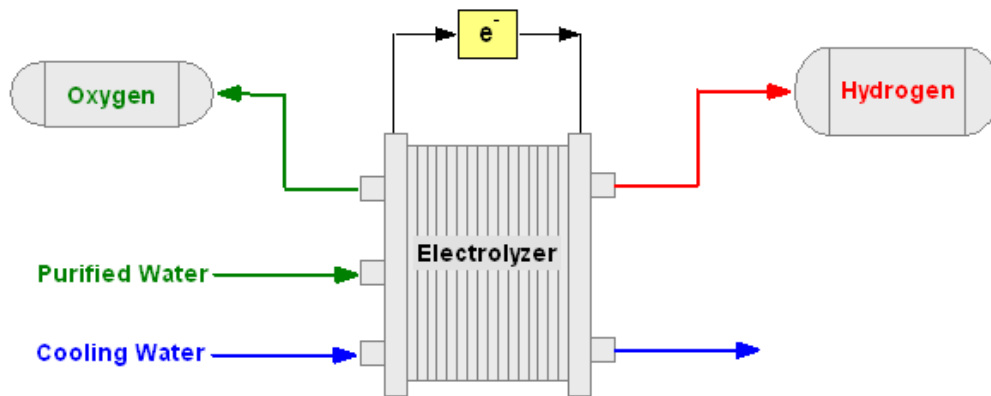
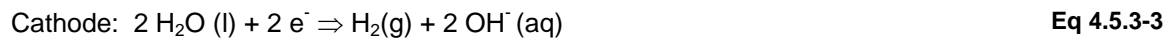

Figure 4.5.3–1: Electrolyzer principle

The decomposition of water into hydrogen and oxygen can be achieved by passing an electric current (DC) between two electrodes separated by an aqueous electrolyte with good ionic conductivity. The total reaction for splitting water is:



For this reaction to occur a minimum electric voltage must be applied to the two electrodes. This minimum voltage, or reversible voltage, can be determined from Gibbs energy for water splitting (Eq 4.5.3-12). In an alkaline electrolyzer the electrolyte is usually aqueous potassium hydroxide (KOH), where the potassium ion K^+ and hydroxide ion OH^- take care of the ionic transport. The anodic and cathodic reactions taking place here are:



In an alkaline solution the electrodes must be resistant to corrosion, and must have good electric conductivity and catalytic properties, as well as good structural integrity, while the diaphragm should have low electrical resistance. This can, for instance, be achieved by using anodes based on nickel, cobalt, and iron (Ni, Co, Fe), cathodes based on nickel with a platinum activated carbon catalyst (Ni, C-Pt), and nickel oxide (NiO) diaphragms.

4.5.3.1 Electrochemical model

The electrode kinetics of an electrolyzer cell can be modeled using empirical current-voltage (I-U) relationships. Several empirical I-U models for electrolyzers have been suggested [4,5,6,7]. In order to properly model the I-U curve for a given temperature, overvoltages and ohmic resistance are taken into account, as proposed in [1].

CURRENT-VOLTAGE CHARACTERISTIC (PER CELL)

$$U_{\text{cell}} = U_{\text{rev}} + r' \cdot \frac{I_{\text{ely}}}{\text{AREA}} + s' \cdot \log \left[\frac{t' \cdot I_{\text{ely}}}{\text{AREA}} + 1 \right] \quad \text{Eq 4.5.3-4}$$

With:

$$r' = r_1 + r_2 \cdot T_{\text{ely}} \quad \text{Eq 4.5.3-5}$$

$$s' = s_1 + s_2 \cdot T_{\text{ely}} + s_3 \cdot T_{\text{ely}}^2 \quad \text{Eq 4.5.3-6}$$

$$t' = t_1 + \frac{t_2}{T_{\text{ely}}} + \frac{t_3}{T_{\text{ely}}^2} \quad \text{Eq 4.5.3-7}$$

The Faraday efficiency is defined as the ratio between the actual and theoretical maximum amount of hydrogen produced in the electrolyzer. Since the Faraday efficiency comprises the parasitic current losses along the gas ducts, it is often called the current efficiency. The parasitic currents increase with decreasing current densities due to an increasing share of electrolyte and therefore also a lower electrical resistance [7]. Furthermore, the parasitic current in a cell is linear to the cell potential (Eq 4.5.3-1). Hence, the fraction of parasitic currents to total current increases with decreasing current densities. An increase in temperature leads to a lower resistance, more parasitic current losses, and lower Faraday efficiencies. An empirical expression that accurately depicts these phenomena for a given temperature is:

FARADAY EFFICIENCY

$$\eta_f = \left[\frac{I_{\text{density}}^2}{a_1 + I_{\text{density}}^2} \right] \cdot a_2 \quad \text{Eq 4.5.3-8}$$

According to Faraday's law, the production rate of hydrogen in an electrolyzer cell is directly proportional to the transfer rate of electrons at the electrodes, which in turn is equivalent to the electrical current in the external circuit. Hence, the total hydrogen production rate in an electrolyzer, which consists of several cells connected in series, can be expressed as:

HYDROGEN PRODUCTION

$$\dot{n}_{\text{H}_2} = \eta_f \cdot N_{\text{cells}} \cdot \frac{I_{\text{ely}}}{n \cdot F} \quad \text{Eq 4.5.3-9}$$

The oxygen production rate is simply found from stoichiometry (Eq 4.5.3-3), which on a molar basis is:

OXYGEN PRODUCTION

$$\dot{n}_{\text{O}_2} = 0.5 \cdot \dot{n}_{\text{H}_2} \quad \text{Eq 4.5.3-10}$$

The generation of heat in an electrolyzer is mainly due to electrical inefficiencies. The energy efficiency can be calculated from the thermoneutral voltage (U_{tn}) and the cell voltage (U_{cell}):

ENERGY EFFICIENCY

$$\eta_e = \frac{U_{tn}}{U_{cell}} \quad \text{Eq 4.5.3-11}$$

For a given temperature, an increase in hydrogen production (i.e., an increase in current density) increases the cell voltage, which consequently decreases the energy efficiency. For a given current density, the energy efficiency increases with increasing cell temperature (see Figure 4.5.3–2).

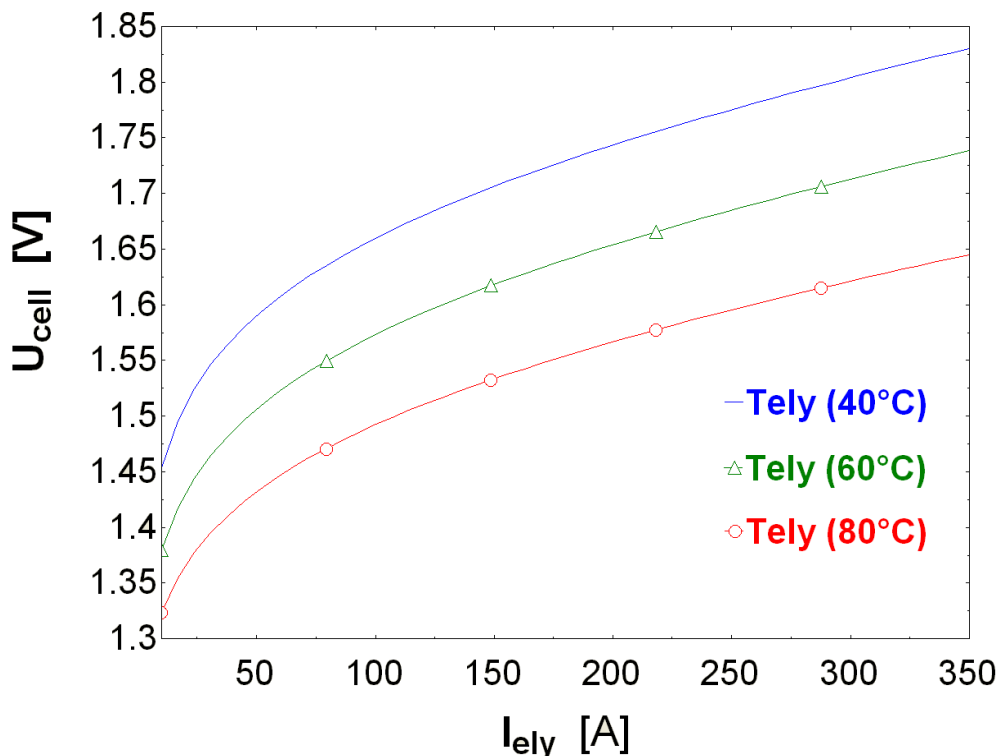

Figure 4.5.3–2: Electrolyzer – Cell voltage vs. Current for different Temperatures

It should be noted here that Eq 4.5.3-11 is only valid for systems where no auxiliary heat is added to the system. If auxiliary heat is added, the voltage may drop into the region between the reversible and thermoneutral voltage, and the efficiency would be greater than 100%. In low-temperature electrolysis, the cell voltage will during normal operation (50-80°C and 40-300 mA/cm²) always be well above the thermoneutral voltage, as observed in Figure 4.5.3–2. However, some initial heating may be required during start-up if the electrolyzer has been allowed to cool down to ambient temperature.

In order to calculate the overall performance of an electrolyzer system, information about number of cells in series and/or parallel per stack and number of stacks per unit is needed. The rated voltage of an electrolyzer stack is found from the number of cells in series, while the number of cells in parallel yields the rated current (and H₂-production). The total power is simply the product of the current and voltage.

4.5.3.2 Thermodynamic model

Thermodynamics provides a framework for describing reaction equilibrium and thermal effects in electrochemical reactors. It also gives a basis for the definition of the driving forces for transport phenomena in electrolytes and leads to the description of the properties of the electrolyte solutions [3]. Below is a description of the thermodynamics of the low-temperature hydrogen-oxygen electrochemical reactions used in the electrolyzer model.

The following assumptions can be made about the water splitting reaction: (a) Hydrogen and air (or oxygen) are ideal gases, (b) water is an incompressible fluid, and (c) the gas and liquid phases are separate. Based on these assumptions the change in enthalpy ΔH , Entropy ΔS and Gibbs Energy ΔG of the water splitting reaction can be calculated with reference to pure hydrogen (H_2), oxygen (O_2), and water (H_2O) at a standard temperature and pressure (25°C and 1 atm). The total change in enthalpy for splitting water is the enthalpy difference between the products (H_2 and O_2) and the reactants (H_2O). The same applies for the total change in entropy. The change in Gibbs energy is expressed by:

GIBBS FREE ENERGY

$$\Delta G = \Delta H - T_{\text{ely}} \cdot \Delta S \quad \text{Eq 4.5.3-12}$$

At standard conditions (25°C and 1 atm) the splitting of water is a non-spontaneous reaction, which means that the change in Gibbs energy is positive. The standard Gibbs energy for water splitting is $\Delta G^0 = 237 \text{ kJ mol}^{-1}$. For an electrochemical process operating at constant pressure and temperature the maximum possible useful work (i.e., the reversible work) is equal to the change in Gibbs energy ΔG . Faraday's law relates the electrical energy (emf) needed to split water to the chemical conversion rate in molar quantities. The emf for a reversible electrochemical process, or the reversible cell voltage, is expressed by:

REVERSIBLE VOLTAGE (PER CELL)

$$U_{\text{rev}} = \frac{\Delta G}{n \cdot F} \quad \text{Eq 4.5.3-13}$$

The total amount of energy needed in water electrolysis is equivalent to the change in enthalpy ΔH . From Eq 4.5.3-4 it is seen that ΔG includes the thermal irreversibility $T\Delta S$, which for a reversible process is equal to the heat demand. The standard enthalpy for splitting water is $\Delta H^0 = 286 \text{ kJ mol}^{-1}$. The total energy demand ΔH is related to the thermoneutral cell voltage:

THERMONEUTRAL VOLTAGE (PER CELL)

$$U_{\text{tn}} = \frac{\Delta H}{n \cdot F} \quad \text{Eq 4.5.3-14}$$

At standard conditions $U_{\text{rev}} = 1.229 \text{ V}$ and $U_{\text{tn}} = 1.482$, but these will change with temperature and pressure. In the applicable temperature range U_{rev} decreases slightly with increasing temperature ($U_{\text{rev}} @ 80^\circ\text{C}, 1 \text{ bar} = 1.184 \text{ V}$), while U_{tn} remains almost constant ($U_{\text{tn}} @ 80^\circ\text{C}, 1 \text{ bar} = 1.473 \text{ V}$). Increasing pressure increases U_{rev} slightly ($U_{\text{rev}} @ 25^\circ\text{C}, 30 \text{ bar} = 1.295 \text{ V}$), while U_{tn} remains constant.

4.5.3.3 Thermal model

The temperature of the electrolyte of the electrolyzer can be determined using simple or complex thermal models, depending on the need for accuracy. Assuming a lumped thermal capacitance

model, the overall thermal energy balance can be expressed as a linear, first order, non-homogeneous differential equation. Type 160 can calculate Tstack in 3 different ways:

- TMODE=1: T is given as Input
- TMODE=2: T is calculated based on a simple quasi-static thermal model
- TMODE=3: T is calculated based on a complex lumped capacitance thermal model

OVERALL ENERGY BALANCE

$$C_T \cdot dTdt_{ely} = \dot{Q}_{gen} - \dot{Q}_{loss} - \dot{Q}_{cw} \tag{Eq 4.5.3-15}$$

GENERATED THERMAL ENERGY

$$\dot{Q}_{gen} = N_{cells} \cdot I_{ely} \cdot (U_{cell} - U_{tn}) \tag{Eq 4.5.3-16}$$

HEAT LOSSES TO AMBIENT

$$\dot{Q}_{loss} = \frac{1}{R_T} \cdot (T_{ely} - T_{amb}) \tag{Eq 4.5.3-17}$$

AUXILIARY COOLING REQUIREMENTS

$$\dot{Q}_{cw} = C_{p,H2O} \cdot (T_{cw,out} - T_{cw,in}) \tag{Eq 4.5.3-18}$$

The first term on the right hand side of Eq 4.5.3-15 is the internal heat generation, the second term the total heat loss to the ambient, and the third term the auxiliary cooling demand. The overall thermal capacity C_t and resistance R_t for the electrolyzer, and the UA-product for the cooling water heat exchanger are the constants that need to be determined analytically or empirically prior to solving the thermal equations. It should be noted that the thermal model presented here is on a per stack basis. In Type 160, UA is given as a function of electrolyzer current:

$$UA_{HX} = h_1 + h_2 \cdot I_{ely} \tag{Eq 4.5.3-19}$$

4.5.3.4 Additional information

Type 160 is also described in an EES-based executable program distributed with TRNSYS 17: %TRNSYS17%\Documentation\HydrogenSystemsDocumentation.exe

4.5.3.5 External data file

Type 160 reads the electrolyzer performance data from a data file. An example is provided in "Examples\Data Files". The data file should have the following information:

```
<Nb of electrolyzers>
<No of the electrolyzer>, <Name of electrolyzer>
<r1> <r2> <s1> <t1> <t2> <t3> <a1> <a2> <h1> <h2> } For each electrolyzer
```

The parameters that must be provided are described here below:

No	Parameter	Units	Description
1	r1	Ωm^2	Ohmic resistance (Eq 4.5.3-5)
2	r2	$\Omega m^2 / ^\circ C$	Ohmic resistance (Eq 4.5.3-5)

3	s1	V	Overvoltage on electrodes (Eq 4.5.3-6)
4	t1	m ² / A	Overvoltage on electrodes (Eq 4.5.3-7)
5	t2	m ² °C / A	Overvoltage on electrodes (Eq 4.5.3-7)
6	t3	m ² °C ² / A	Overvoltage on electrodes (Eq 4.5.3-7)
7	a1	mA / cm	Faraday efficiency (Eq 4.5.3-8)
8	a2	0..1	Faraday efficiency (Eq 4.5.3-8)
9	h1	W / °C	Convective heat transfer coefficient (Eq 4.5.3-19)
10	h2	W / °C per A	Convective heat transfer coefficient (Eq 4.5.3-19)

EXAMPLE

2

```

1,Alkaline Electrolyzer PHOEBUS (KFA)
8.05031E-05 -2.50410E-07 0.1849 -0.10015 8.4242 247.2663 250.0 0.96 7.0 0.020
2,GHW Electrolyzer (p=30 bar) (Munich Airport)
1.997990E-05 0.0 0.2113 0.01984 0.0 0.0 250.0 0.96 7.0 0.0200

```

4.5.3.6 References

1. Ulleberg Ø. (2002) Modeling of advanced alkaline electrolyzers: a system simulation approach. *Int. J. Hydrogen Energy* 28(1): 7-19.
2. Ulleberg Ø. (1998) Stand-Alone Power Systems for the Future: Optimal Design, Operation & Control of Solar-Hydrogen Energy Systems. PhD thesis, Norwegian University of Science and Technology, Trondheim.
3. Rousar I. (1989) Fundamentals of electrochemical reactors. In *Electrochemical Reactors: Their Science and Technology Part A*, Ismail M. I. (Eds), Elsevier Science, Amsterdam.
4. Griesshaber W. and Sick F. (1991) Simulation of Hydrogen-Oxygen-Systems with PV for the Self-Sufficient Solar House (in German). FhG-ISE, Freiburg im Breisgau.
5. Havre K., Borg P. and Tømmerberg K. (1995) Modeling and control of pressurized electrolyzer for operation in stand alone power systems. In *Proceedings of 2nd Nordic Symposium on Hydrogen and Fuel Cells for Energy Storage*, January 19-20, Helsinki, Lund P. D. (Ed.), pp. 63-78.
6. Vanhanen J. (1996) On the Performance Improvements of Small-Scale Photovoltaic-Hydrogen Energy Systems. Ph.D. thesis, Helsinki University of Technology, Espoo, Finland.
7. Hug W., Divisek J., Mergel J., Seeger W. and Steeb H. (1992) Highly efficient advanced alkaline electrolyzer for solar operation. *Int. J. Hydrogen Energy* 17(9): 699-705